

31320 / 40141**DODGE FRONT HITCH**

6/13/2007

GROSS LOAD CAPACITY WHEN USED AS A WEIGHT CARRYING HITCH: 5,000 LBS. TRAILER WEIGHT & 500 LBS. TONGUE WEIGHT.

GROSS LOAD CAPACITY WHEN USED AS A STRAIGHT LINE PULL: 9,000 LBS. MAX. LINE PULL.

*****DO NOT EXCEED VEHICLE MANUFACTURER'S RECOMMENDED TOWING CAPACITY.*****

Parts List			
ITEM	QTY	PART NUMBER	DESCRIPTION
1	1	CM-438-FW	7/16 " FISHWIRE TOOL
2	6	7/16 - 14 x 1 3/4	CARRIAGE BOLT
3	6	7/16-14	LARGE HEX FLANGE NUT
4	6	CM-SP2	.250 x .88 x 2.25" SQUARE HOLE SPACER

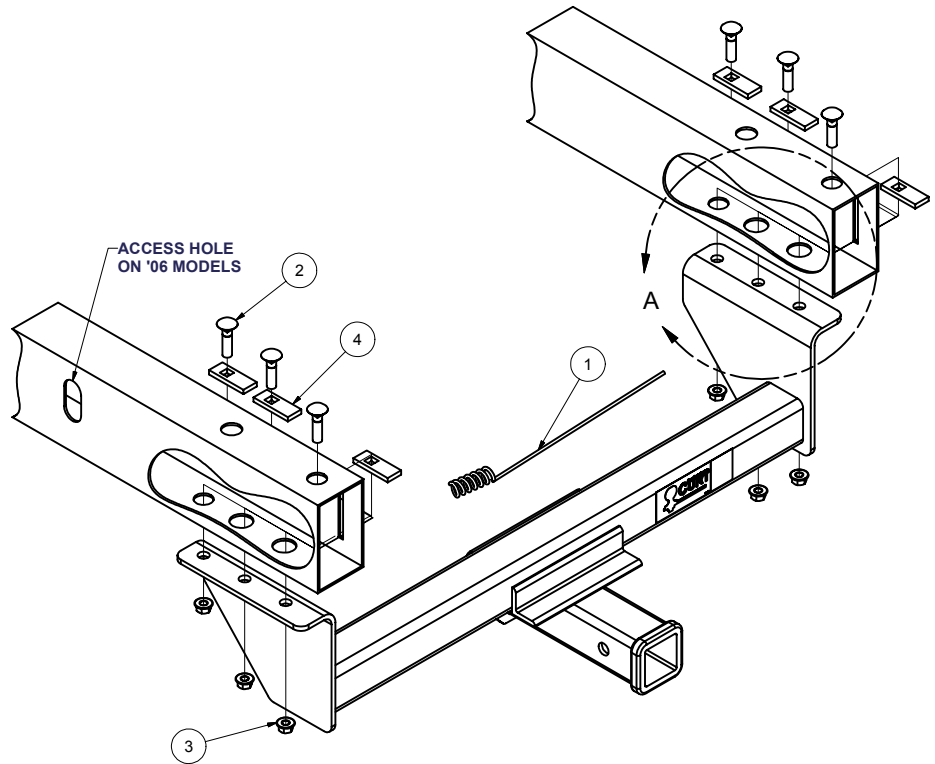
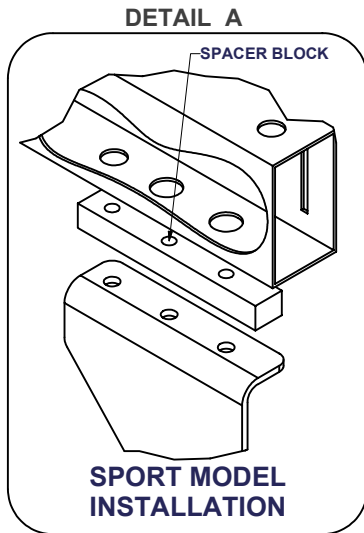

HITCH WEIGHT: 32 LBS.

INSTALL TIME: 30 MINUTES

INSTALL NOTES:

- DRILLING REQUIRED
- '06 1/2 TON REQUIRES DRILLING AND FASCIA TRIMMING

INSTALLATION STEPS**NOTE:**

(For '06 models and later - The hitch must be used as a template to mark and drill holes as required.)

- 1) Insert the carriage bolt spacers through the frame access slot on the inside surface of the frame.
- 2) Use the fishwire provided to install the carriage bolts into the frame as shown. Be sure to pass the fishwire through the spacer previously installed before attaching it to the bolt. Install the rear bolt first, the center bolt second and the front bolt last. (both sides)
- 3) When all hardware is installed properly raise the hitch into position and attach a 7/16" flange nut to each bolt. (Trim front fascia as needed for hitch clearance.)
- 4) Torque all fasteners to 50ft-lbs.

Note: If installing this hitch on a sport model you must use a 1" thick spacer block kit (31320-SK) or remove the metal reinforcement assembly and notch the front fascia.

PERIODICALLY CHECK THIS RECEIVER HITCH TO ENSURE THAT ALL FASTENERS ARE TIGHT AND THAT ALL STRUCTURAL COMPONENTS ARE SOUND.

Curt Manufacturing Inc., warrants this product to be free of defects in material and/or workmanship at the time of retail purchase by the original purchaser. If the product is found to be defective, Curt Manufacturing Inc., may repair or replace the product, at their option, when the product is returned, prepaid, with proof of purchase. Alteration to, misuse of, or improper installation of this product voids the warranty. Curt Manufacturing Inc.'s liability is limited to repair or replacement of products found to be defective, and specifically excludes liability for incidental or consequential loss or damage.

10/7/2006